

## 120 Full Automatic Aerosol Spray Online Weight Detecting Machine

This machine is adopting stable high sensitive weighting sensor and signal collecting module, processing high speed calculating with PLC, together with an Intuitive humanizing interface, well-designed turntable conveying mechanism, giving advantages such as good stability, fast response, high accuracy and so on to it, making it late-model device for online weight detecting, and an ideal choice for manufacturer of aerosol.

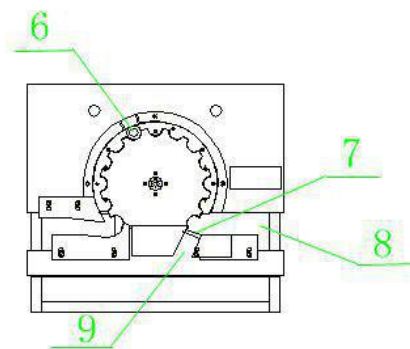
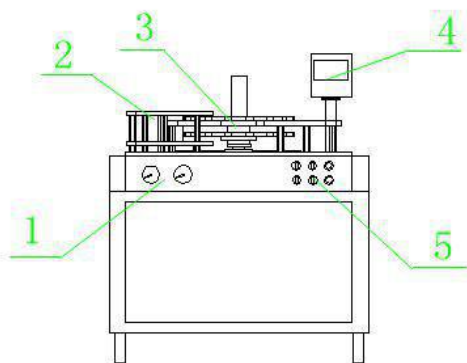

- 1 Pressure gauge
- 2 Tank separating guardrail
- 3 Bottle separating turntable
- 4 PLC control center
- 5 Operating button
- 6 Weighing device
- 7 Tank picking device
- 8 Conforming product track
- 9 Nonconforming product track

## Main technical specification

Suitable aerosol tank(special specification can be customized)	Height(mm)105-350
	Diameter(mm)35-70
Testing speed	40-60 tank/min
Power supply voltage	AC380V 50HZ
Electric power consumption	0.3KW
Weighing range	With in 1.5KG
Static deviation	0g
Dynamic deviation	±1.0g
Air pressure (Mpa)	0.65-1
Maximum gas consumption (cubic / min)	0.5