

120 Automatic Aerosol Cap Pressing Machine

Composed of four parts: the automatic cap feeding, sorting, rotating and buckling. Full automatic control, without manual operation, saving time and effort. Automatic stop in condition of cover or tank absence, making it safe and reliable. Suitable for buckling requirement of different specifications of aerosol tanks. Can reduce labor by 1-2, improving productivity, making it an ideal choice for manufacturers of aerosol.

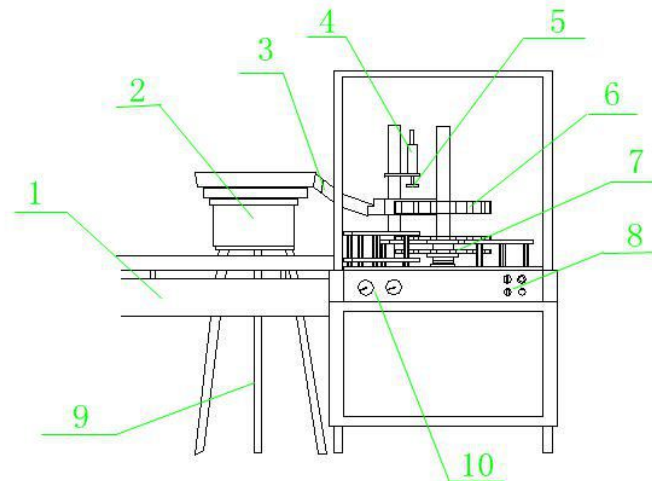

- 1 tank inlet convey belt
- 2 vibration cover sorting machine
- 3 cover outlet track
- 4 cover buckling machine
- 5 cover buckling rod
- 6 cover separating turntable
- 7 tank separating turntable
- 8 working button
- 9 adjustable foot stool
- 10 working pressure gauge

Main technical specification

Suitable aerosol tank(special specification can be customized)	Height(mm)80-350
	Diameter(mm)35-65
Working pressure (Mpa)	0.65-1
Power supply voltage	AC380V 50HZ
Electric control cabinet and motor	Explosion-proof/Flame-proof
Maximum gas consumption (cubic/min)	0.8
Motor power(Kw)	1.1
Productivity (tank/min)	40-60